

TEST DEVICE
TEST GAUGE, SAFETY VERSION
ACC. TO DIN EN 837-1 (S)



Nominal size 160
Class 0,6
complete stainless steel

For mobile pressure measurement with high accuracy.
 For gaseous and liquid, aggressive, not highly viscous or crystallising media.
 Delivery of the test gauge is made in a service case together with different connection armatures and a test certificate.



Type	8701
Nominal size	160
Accuracy class	Class 0,6 acc. to EN 837-1
Display range	0...0,6 up to 0...600 bar negative or negative and positive overpressure
Field of application	Static load: up to full scale value Alternating load: max. 90% of full scale value short-time: 1,3 x full scale value
Case	Stainless steel with break-proof partition (Solidfront) and blow-out back
Bayonet ring	Stainless steel
Measuring unit	Stainless steel 316L <100 bar circular form; ≥100 bar screw shape (coil spring)
Pressure connection	Stainless steel 316L, angle valve with test socket M20x1,5-LH and adjusting nut M20x1,5
Connection position	Lateral at 3 o'clock
Window	Multi-layer safety glass
Pointer mechanism	Stainless steel
Dial	Aluminium white, scale black
Pointer	Knife edge pointer, Aluminium black
Protection class	IP54 EN 60529 / IEC529
Temperatures	Surrounding: -40...+60°C, medium: max. +200°C
Temperature influence	At deviation of the reference temperature (+20°C) at measuring system: max.±0,4%/10 K of the respective full scale value
Adjustment medium	≤ 25 bar: gas; > 25 bar liquid, other adjustment medium on request/arrangement
Weight	Incl. service case and accessories ca. 3,8 kg
Accessories	1 service case 270 x 180 x 135 mm 1 adjusting nut M20 x 1,5 DIN 16283 1 adapter M20 x 1,5, with test flange 60 x 25 x 10 mm 2 fastening screws M8 2 hexagon nuts M8 3 sealings 16,5 x D17 2 distance bushings Works test certificate, test certificate, list of individual values
Options	Fork for round flanges Oxygen version

Type 8701

Dimensional drawing

Dimension in mm



DRUCK & TEMPERATUR

Type 8701

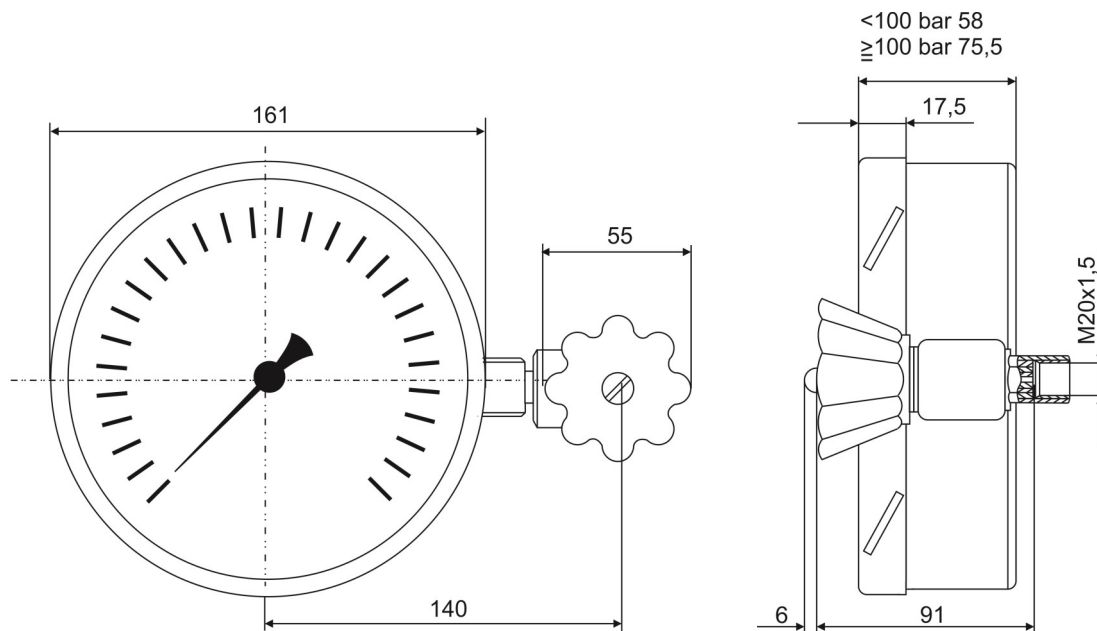

Accessories

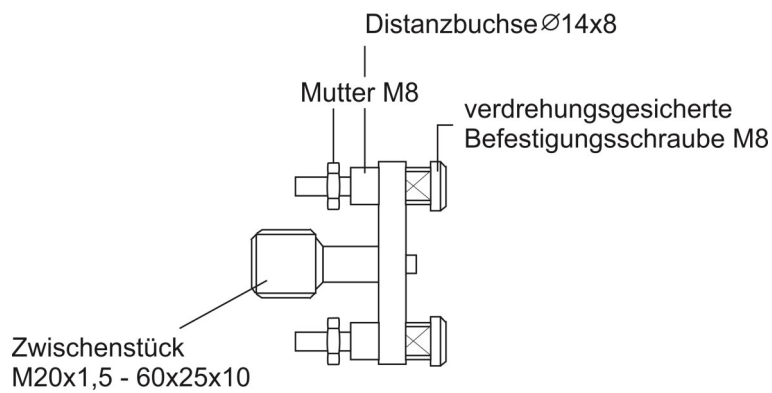

Fork option

