

# WELDING SOCKET WITH SEALING SURFACE AND WITH THREAD

For the installation of valves and indicating devices,  
for example hydraulic systems and container construction.

Welding sockets of steel are delivered with a copper sealing ring,  
welding sockets of stainless steel with a stainless steel sealing.

Materials: Steel St37 (S235JR)  
Creep resistant steel C22.8  
Stainless steel 1.4571, 1.4404



On request, welding sockets of creep resistant steel C22.8 and stainless steel are available with a material test certificate.

## Dimension drawing for welding socket with thread G1/2

Dimensions in mm

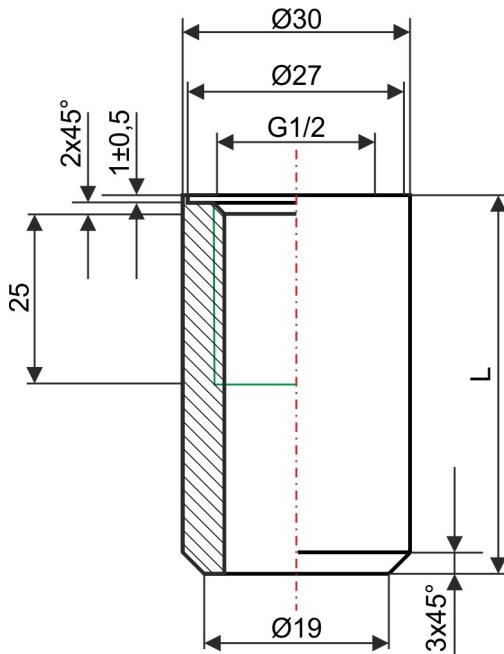

Order number	Length L	Thread	Material
20 10 62	30*	G $\frac{1}{4}$	Steel St37 (Steel C22.8 please quote when ordering)
20 41 52	20*	G $\frac{1}{2}$	
20 11 52	30		
20 13 52	40		
20 21 52	50		
20 25 52	60		
20 28 52	80		
20 31 52	100		
20 71 20	20*		Stainless steel
20 71 30	30		
20 71 50	50		
20 71 60	60		
20 71 80	80		
20 71 100	100		

\* diverging dimensions  
other lengths and threads on request